

# GAS TRANSMITTERS ROOM / DUCT 4-20mA

## E3..

These products detect the presence of the relevant gas and give a 4-20mA output signal linear across the selected range.



E3..R                      E3..D

Suitable for monitoring & ventilation applications.  
DO NOT use on safety or hazardous applications.  
A filter for minor dirt/dust protection is fitted.  
DO NOT EXPOSE TO EXTREME AMBIENT/MEDIA OR OILY/DIRTY CONDITIONS.  
A calibration check after 3 years operation may be required - a yearly calibration check is recommended.  
Typical Accuracy <5%  
Ambient - 20/+50°C 15-90% RH non-condensing  
Sensor: Electrochemical - higher performance than semi-conductor types.  
Consumption 25mA Enclosure flammability = UL94-V0

Type	Gas Detected	Mounting	Range	Approx Response Time	Supply ±20%	Output	Vap. Density Air = 1	Max Resistance Ω	Enclosure
<b>E3-025R</b>	Oxygen	O <sub>2</sub>	Wall 0-25%	≤15s	24VDC	4-20mA loop	1.11	450	IP65
<b>E3-CM100R</b>	Carbon Monoxide	CO	Wall 0-100ppm	≤30s	24VDC	4-20mA loop	0.97	450	IP65
<b>E3-CM200R</b>	Carbon Monoxide	CO	Wall 0-200ppm	≤30s	24VDC	4-20mA loop	0.97	450	IP65
<b>E3-CM300R</b>	Carbon Monoxide	CO	Wall 0-300ppm	≤30s	24VDC	4-20mA loop	0.97	450	IP65
<b>E3-CM300D</b>	Carbon Monoxide	CO	<b>Duct</b> 0-300ppm	≤30s	24VDC	4-20mA loop	0.97	450	IP65
<b>E3-CM500R</b>	Carbon Monoxide	CO	Wall 0-500ppm	≤30s	24VDC	4-20mA loop	0.97	450	IP65
<b>E3-HS5R</b>	Hydrogen Sulphide	H <sub>2</sub> S	Wall 0-5ppm	≤35s	24VDC	4-20mA loop	1.19	450	IP65
<b>E3-HS10R</b>	Hydrogen Sulphide	H <sub>2</sub> S	Wall 0-10ppm	≤35s	24VDC	4-20mA loop	1.19	450	IP65
<b>E3-SD10R</b>	Sulphur Dioxide	SO <sub>2</sub>	Wall 0-10ppm	≤15s	24VDC	4-20mA loop	2.26	450	IP65
<b>E3-ND5R</b>	Nitrogen Dioxide	NO <sub>2</sub>	Wall 0-5ppm	≤35s	24VDC	4-20mA loop	2.62	450	IP65
<b>E3-ND10R</b>	Nitrogen Dioxide	NO <sub>2</sub>	Wall 0-10ppm	≤35s	24VDC	4-20mA loop	2.62	450	IP65
<b>E3-CL5R</b>	Chlorine	Cl <sub>2</sub>	Wall 0-5ppm	≤60s	24VDC	4-20mA loop	2.47	450	IP65
<b>E3-CL10R</b>	Chlorine	Cl <sub>2</sub>	Wall 0-10ppm	≤60s	24VDC	4-20mA loop	2.47	450	IP65

### DIMENSIONS:

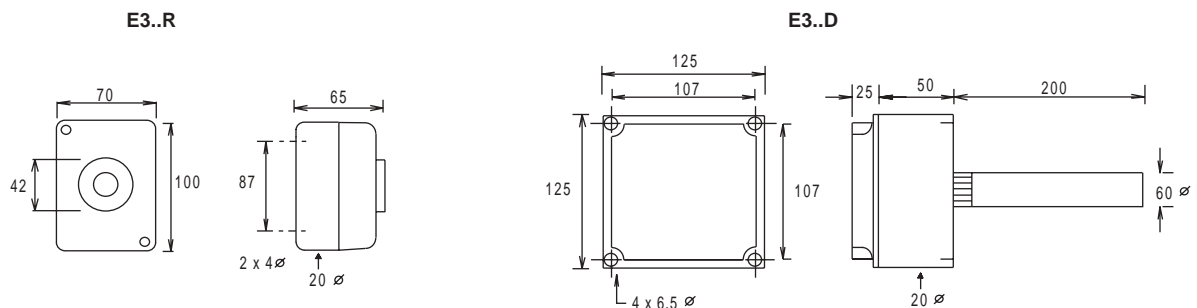

### WIRING:

Screw Terminals provided.

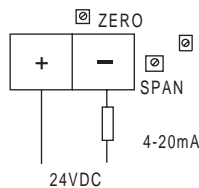

Do not solder wires to the pcb as this can cause leakage of the electrolyte.

TOXIC LEVEL GUIDE:	Long term 8 hours	Short term 15 mins	Instantaneous	Standard Range	Mounting Height
CO	50ppm	300ppm	400ppm	0-300ppm	1.6 - 2m
H <sub>2</sub> S	10ppm	15ppm	50ppm	0-20ppm	1.6 - 2m
SO <sub>2</sub>	2ppm	5ppm	10ppm	0-5ppm	See gas density to air
NO <sub>2</sub>	3ppm	5ppm	10ppm	0-5ppm	See gas density to air
CL <sub>2</sub>	0.5ppm	5ppm	5ppm	0-5ppm	See gas density to air
O <sub>2</sub>	Deficiency 19%	Normal 21%	Enrichment 23%		See gas density to air

### INSTALLATION:

Mount in an area where good representative monitoring can be achieved. All sensors should be installed according to local regulations. Avoid areas of poor circulation. **E3..D** duct units - install in a straight duct run - avoid high pressure and turbulent areas.

All sensors must be mounted according to gas density relative to air ie. check the weight of the gas.

Terminals 0.5-2.5mm<sup>2</sup> Min cable size 7/0.2mm

Max length 300m Screened cable is recommended.

The screen should be earthed at controller end only.

Keep away from power cables or units which may cause interference.

### CAUTION:

Contains small amounts of toxic chemicals which do not present a safety hazard - handle & dispose of according to local regulations.

These devices are suitable for low voltage supply only.

Observe all relevant safety precautions, wiring/earthing regulations and electrical ratings.

Device should be checked by a qualified technician before applying any voltage.

Observe precautions for handling electrostatic sensitive devices.

Ensure electrical entry hole is completely sealed for all IP65/weatherproof models.

Always ensure the device operates correctly. If failure of the device can cause damage a safety backup control should be fitted.

All data is for guidance purposes only, subject to change without prior notice and not guaranteed to be absolutely correct unless confirmed by us in writing.

